



**ASCEND**<sup>TM</sup>

**KAYAK OWNER'S MANUAL**

# TABLE OF CONTENTS

## PRODUCT

Introduction	3
10Si	4
H10	6
H12	8
9R Sport	10
10T	12
12T	14
128X	16
133X	18
Model Overview – Sit In/Hybrid	20
Model Performance Rating Matrix – Sit In/Hybrid	21
Model Overview – Sit On Top	22
Model Performance Rating Matrix – Sit On Top	23

## FEATURE INFORMATION

128X Yak Power/12-Volt Wiring Information	24
133X Yak Power/Trolling Motor Wiring Information	25
133X Trolling-Motor Options	26
Universal Accessory Rail Overview	27
Adjusting Your Kayak's Foot Braces	28
Adjusting Your Kayak's Seat (H10, H12, 10T, and 10Si)	29
Adjusting Your Kayak's Seat (12T)	30
General Kayak Information	31



ASCEND kayaks are molded exclusively from AQUATUF® high-density polyethylene and are recyclable

## WARRANTY AND REGISTRATION

Kayak Limited Warranty	32
Arbitration Opt-Out Notice	38
Notes	39
Manufacturer's Statement of Origin to a Boat	40
First Assignment	41

## IMPORTANT

Ensure you understand and can effectively use safety equipment by taking a prequalified instruction/practice course.



The Certified Advantage  
The National Marine Manufacturers Association® (NMMA) Certified label on an ASCEND kayak lets you know it was built to meet, and often exceed, strict quality and safety standards established by the U.S. Coast Guard and the American Boat & Yacht Council. Certified boats must also pass rigorous annual inspections from independent third-party inspectors. As a result, U.S. Coast Guard statistics have shown NMMA-certified boats to be safer than noncertified boats.

For Ascend Kayak models, dealers, and contact information, visit <https://www.ascendkayaks.com>

## INTRODUCTION



**CONGRATULATIONS** on your purchase of another high-quality product from ASCEND®. Our kayaks are designed to provide a unique mix of stability, functionality, and comfort for paddlers of all skill levels. ASCEND designers work to craft the highest-quality gear at the best possible value. Your new kayak is manufactured from superior materials and state-of-the-art processes to ensure maximum durability. With proper care and maintenance, you can expect years of enjoyment from your new ASCEND kayak.

## SAFETY FIRST!

Read the entire Owner's Manual prior to using this product. We also highly recommend you take a basic course on boating and safety. Once you've learned proper technique and safety, it's time to make some memories!

The user of this product should:

- Understand that participating in paddle-sports could result in serious injury or death if done improperly
- Observe and follow all safety rules and standards
- Read the entire Owner's Manual prior to use
- First obtain paddle-sport instructions from a certified instructor
- Obtain certified first-aid and rescue training and carry recommended certified equipment
- Always wear a nationally approved personal flotation device (PFD)
- Dress appropriately for weather conditions. Cold water and/or cold weather can result in hypothermia
- Never paddle alone, Paddle with a friend
- Never use alcohol or mind-altering drugs prior to using this product
- Never paddle in flood-level conditions. Be aware of river water levels, tide changes, dangerous currents, and dangerous weather conditions

- Know they are personally responsible for his/her own safety and assumes all risk and responsibility for any injury or death which might occur while using any ASCEND kayak
- Always be on the lookout for hazards, such as other boats, weather, and natural disasters
- Check their equipment prior to each use for signs of wear or failure
- Always wear a helmet
- Your Ascend Kayak is not intended for nighttime use. If you intend to operate your kayak between "sunset and sunrise" equip your kayak with the appropriate lighting per 33 C.F.R. Part 83.20 - Lights and Shapes. Lighting requirements vary depending on how your kayak is propelled. Check local and state regulations for additional requirements
- Level load your kayak. A kayak that is unevenly loaded can be unstable and reduce performance

## 10Si PRODUCT OVERVIEW

ASCEND introduces 10Si, a 10' kayak for adventurers and anglers seeking performance and stability in a small form factor sit-in. Designed with versatility in mind, it suits recreational paddlers and fishermen alike. Ascend® engineers have created a lightweight, high-capacity boat with class-leading stability, while providing superior performance and exceptional comfort in a well-thought-out ergonomic design.

It is ideally suited for beginning paddlers and avid anglers. The 10Si Sit-In Kayak delivers exceptional performance on the water at an exceptional value. Length: 10'2", Width: 32.9", Approximate boat weight including seat: 57 lbs. Max Wt. Cap.: 350 lbs. Made in USA.

**Accessory Rails:** 2 forward 12" and 2 mid 6" accessory rails recessed into the port and starboard gunnels maximize flexibility by allowing you to choose your own rigging locations and quickly add virtually any aftermarket accessory that attaches to a rail system (e.g., fish finders, flex-arm transducers, lights, rod tubes, rod tenders, or camera mounts (*Accessories not included*)).

**Adjustable Foot Braces:** Allow a comfortable fit for anyone approximately 5'2" – 6'4" (1.57–1.93m) tall. Can be moved fore and aft to balance the load to maximize performance.

**Bow Bungee:** Allows quick-access and versatile stowage.

**Bungee Paddle/Rod Keepers:** Port and starboard molded pockets allow paddle or rod positioning for multiple rods.

**Comfort Grip Handles:** Molded-over rubber-grip handles on bow and stern make transporting the kayak much easier.

**Drain Plug:** Threaded, sealed drain plug allows you to easily drain excess water from the boat.

**Large Multipurpose Sternwell:** Expanded cockpit behind the seat for additional stowage. Can fit all types of cargo, (e.g., small coolers, buckets, standard milk crate, 5-gal. (18.93L) bucket or bait tank, dry bags, or camping gear). Securely nests Ascend® Heavy-Duty Kayak Crate.

**Multipurpose Dash:** 2 deep molded catch-all trays and drink holder.

**Paddle Holders:** Quick-hold molded paddle holders integrated into the cockpit ring allow for a temporary break from paddling or a quick cast.

**Removable Seating System with Friction-Lock Bungee Hold Downs:** Advanced ergonomic seat design with positive friction-lock bungee hold downs for easy adjustments and all-day comfort. Can be removed for use onshore.

**Tunnel Hull Design:** Custom-crafted with the help of advanced hydrostatic stability simulation, to deliver maximum stability and industry-leading capacity. Excellent primary and secondary stability, as well as straight tracking and easy paddling.



# Kayak Anatomy

## 10Si SIT-IN KAYAK

10Si model shown w/all accessories. Models and accessories will vary.

- Length: 10'2" (3.1m)
- Width: 32.9" (83.56cm)
- Weight w/Seat: 57 lbs. (25.85kg)
- Max. Capacity: 350 lbs. (158.76kg)
- Cockpit: 38.3"L x 23.9"W (97.28cm x 60.71cm)

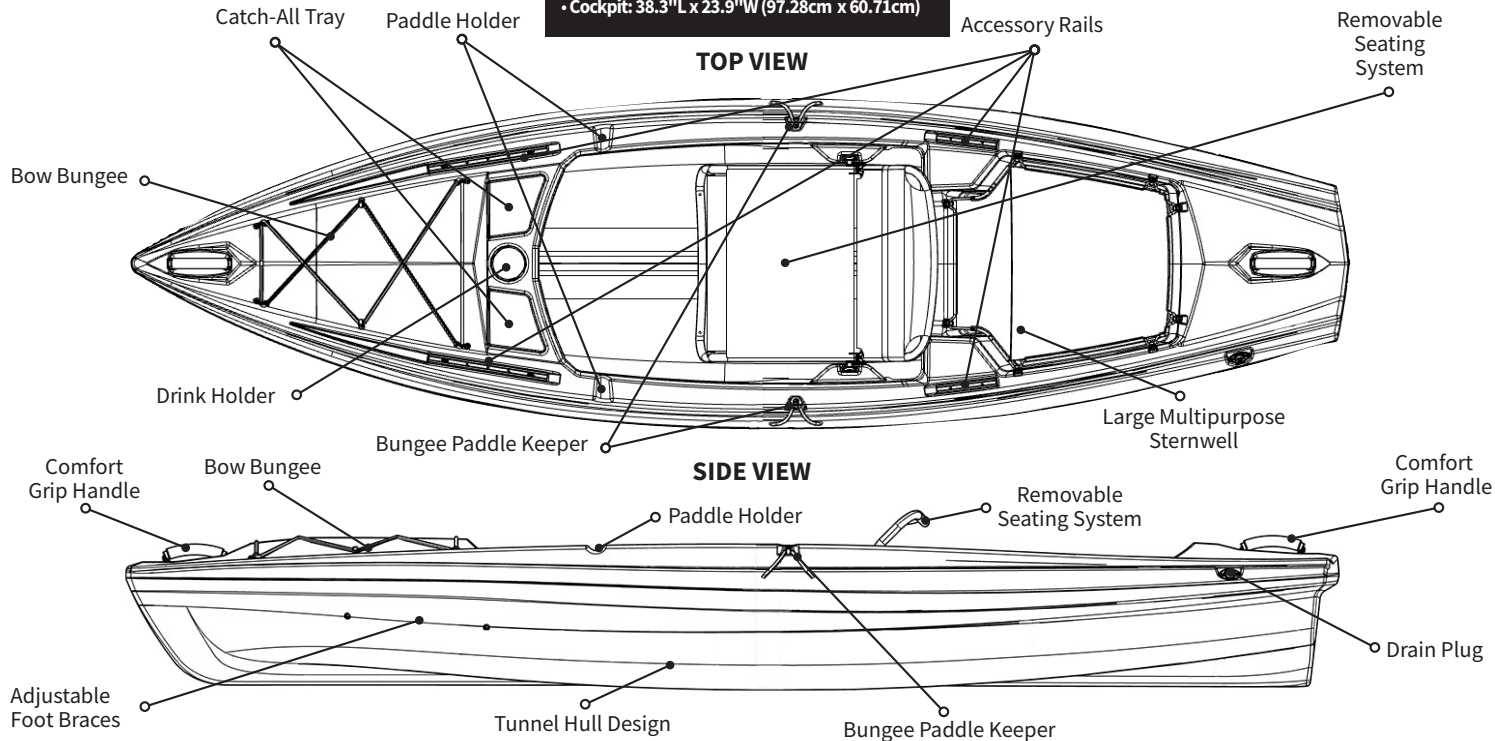

## H10 PRODUCT OVERVIEW

---

The H10 kayak puts all the great features boaters love about the H12 into a nimble, easy-to-carry 10' package. For performance, it features our exclusive tunnel hull design for great stability at rest and straight tracking underway. The hull even features a stepped bow and keel to slice through chop and waves. Above the water, the H10 is just as impressive, delivering exceptional storage capabilities in the fore and aft compartments—both with soft covers for easy access on the

go. And then inside the cockpit, you'll find huge amounts of legroom thanks to the open design. You'll also find that the comfortable seat puts you in the perfect position to access the rod holders just aft of the cockpit, as well as whatever optional accessories you mount on the port and starboard rails. The end result is a stable, nimble fishing and paddling platform with great load-carrying capabilities that are great for a wide range of activities.

**Tunnel Hull:** Custom tunnel-style hull with a stepped keel in the bow and stern to deliver excellent hydrodynamic performance, as well as a solid platform with best-in-class maneuverability in rivers and streams.

**Accessory Rails:** 3 recessed accessory rails preinstalled into the port, starboard, and forward midship gunnels allow you to quickly add virtually any aftermarket accessory that attaches to a rail system (*Accessories not included*).

**Adjustable Foot Braces:** Allow a comfortable fit for anyone approximately 5'2"-6'2" (1.57-1.88m) tall. Adjustments can be made in tandem with the 8" (20.32cm) seat adjustment to balance the load and maximize performance.

**Deluxe Removable Seating System:** Suspended deluxe steel-frame ergonomic cushioned seat with upgraded integration into the kayak and innovative features to keep you high, dry, and comfortable. Positive-friction bungee hold-downs secure the seat while portaging and transporting it. It features 6-position adjustability for maximum comfort while paddling. The removable seat can be used at base camp and includes dual drink holders that rotate 180°.

**Multipurpose Open Deck:** Open deck platform offers maximum storage versatility, including a bow hatch and stern cover.

• **Large Cockpit:** Largest open cockpit on the market allowing for more mobility as well as easy entry and exit - 47.4" L: (1.2m), 23.6" W (59.94cm).

• **Expandable Mesh Bow & Stern Cargo Cover:** Multipurpose bow and stern tankwells sized to accept very large dry bags and plentiful gear options. Covers allow quick access while securely holding gear and can be adjusted to suspend off the bottom of the hull to create a dry, quick-access storage area.

• **Soft Saddlebags:** Port and starboard saddlebags that quickly connect to the under-gunnel D-rings with carabiner clips. Included 2 types: open mesh and waterproof material. Extra carabiner clips included.

• **Dual Flush-Mounted Rod Holders:** Allow secure transport of various types of rods and reels with quick access while on the water. Rod-leash ready.

• **Performance Grip Handles:** Molded-over bow and stern rubber-grip handles for easy transport. Attached with 1/4" (.64cm) stainless steel bolts.

• **Drain Plug:** Threaded, sealed drain plug allows you to easily drain excess water from the boat.

# Kayak Anatomy

## H10 HYBRID KAYAK

- Length: 10' (3.05m)
- Width: 31" (78.74cm)
- Weight w/Seat: 55 lbs. (24.95kg)
- Max. Capacity: 400 lbs. (181.44kg)

H10 model shown w/all accessories. Models and accessories will vary.

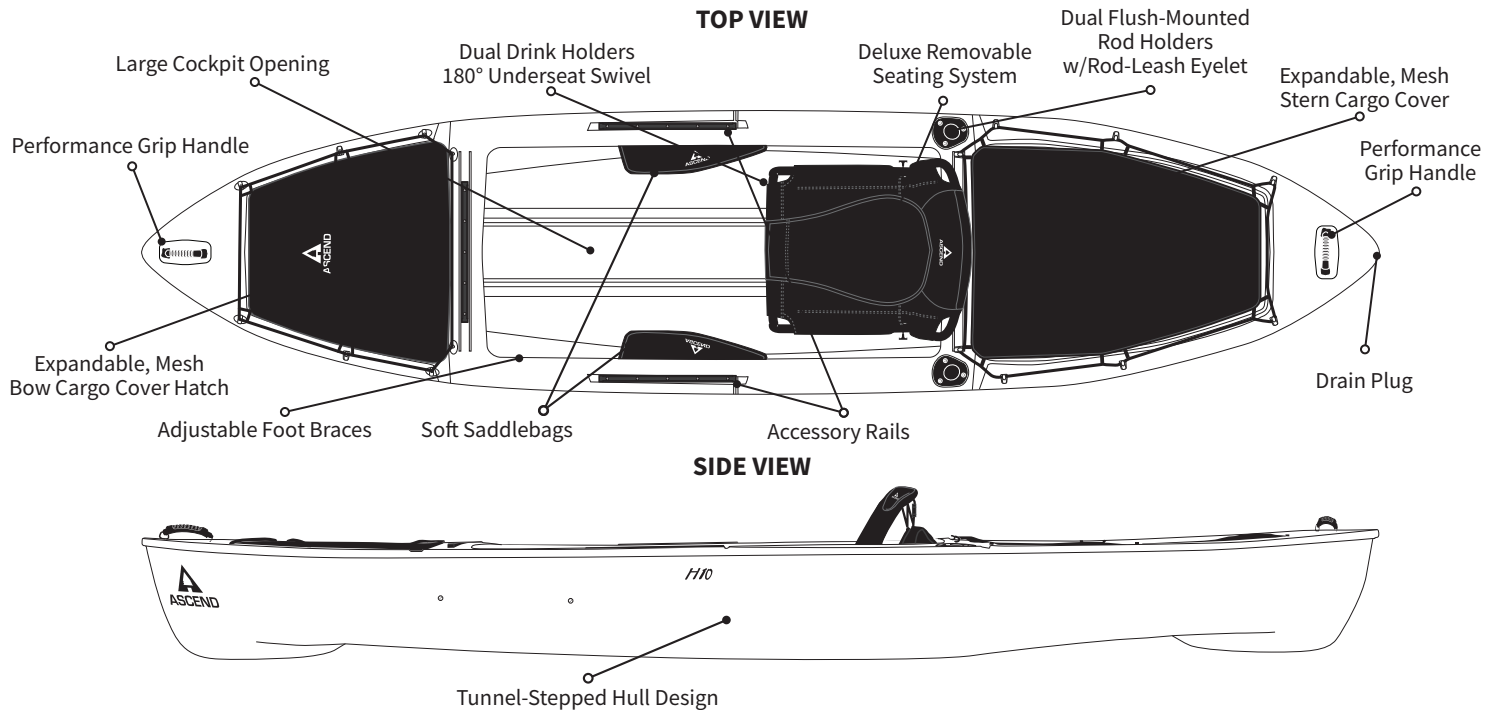

## H12 PRODUCT OVERVIEW

The H12 sit-in hybrid kayak delivers a unique blend of performance, storage capabilities, and rigging characteristics to be an all-species angling kayak. It's the perfect craft for overnight expeditions, yet nimble and balanced enough for day trips. The hybrid tunnel hull provides great primary and secondary stability, as well as an excellent standing and fishing platform. The stepped bow and stern keel design will punch through surf and slide into the backwaters, all

while delivering great maneuverability. Extreme all-day comfort is also designed in with the advanced seating system. Plus, plentiful storage throughout (including innovative storage integrated into the open deck and cockpit), easy entry and exit, and a payload of as much as 450 lbs. (204.12kg) are why ASCEND calls it "The Hybrid 12." It all comes together to make the H12 one of the most versatile fishing kayaks in the industry.

**Tunnel Hull:** Custom tunnel-style hull with a stepped keel in the bow and stern to deliver excellent hydrodynamic performance, as well as a solid platform with best-in-class maneuverability in rivers and streams.

**Accessory Rails:** 3 recessed accessory rails preinstalled into the port, starboard, and forward midship gunnels allow you to quickly add virtually any aftermarket accessory that attaches to a rail system (*Accessories not included*).

**Adjustable Foot Braces:** Allow a comfortable fit for anyone approximately 5'2"-6'2" (1.57-1.88m) tall. Adjustments can be made in tandem with the 8" (20.32cm) seat adjustment to balance the load and maximize performance.

**Deluxe Removable Seating System:** Suspended deluxe steel-frame ergonomic cushioned seat with upgraded integration into the kayak and innovative features to keep you high, dry, and comfortable. Positive-friction bungee hold-downs secure the seat while portaging and transporting it. It features 6-position adjustability for maximum comfort while paddling. The removable seat can be used at base camp and includes dual drink holders that rotate 180°.

**Soft Seat Backpack:** Store wet or dry gear in the quick-connect, removable soft storage backpack.

**Multipurpose Open Deck:** Open deck platform offers maximum storage versatility, including a bow hatch and stern cover.

**Bow Bungee Hold Downs:** Allows you to secure cargo on the bow.

• **Large Cockpit:** Largest open cockpit on the market allowing for more mobility as well as easy entry and exit – 53.5" L (1.36m), 23.5" W (59.69cm).

• **Hard Bow Hatch:** Quick-connect, removable rotomolded hatch with dual-connect carabiners that attach to both ends of the tethering system. It floats!

• **Expandable Mesh Stern Cargo Cover:** Multipurpose stern tankwell sized to accept very large dry bags and plentiful gear options. Cover allows quick access while securely holding gear and can be adjusted to suspend off the bottom of the hull to create a dry, quick-access storage area.

• **Soft Saddlebags:** Port and starboard saddlebags that quickly connect to the under-gunnel D-rings with carabiner clips. Includes 2 types: open mesh and waterproof material. Extra carabiner clips included.

• **Dual Flush-Mounted Rod Holders:** Allow secure transport of various types of rods and reels with quick access while on the water. Rod-leash ready.

• **Performance Grip Handles:** Molded-over bow and stern rubber-grip handles for easy transport. Attached with 1/4" (.64cm) stainless steel bolts.

• **Drain Plug:** Threaded, sealed drain plug allows you to easily drain excess water from the boat.



# Kayak Anatomy

## H12 HYBRID KAYAK

- Length: 12' (3.66m)
- Width: 32" (81.28cm)
- Weight w/Seat: 76 lbs. (34.47kg)
- Max. Capacity: 450 lbs. (204.12kg)

H12 model shown w/all accessories. Models and accessories will vary.

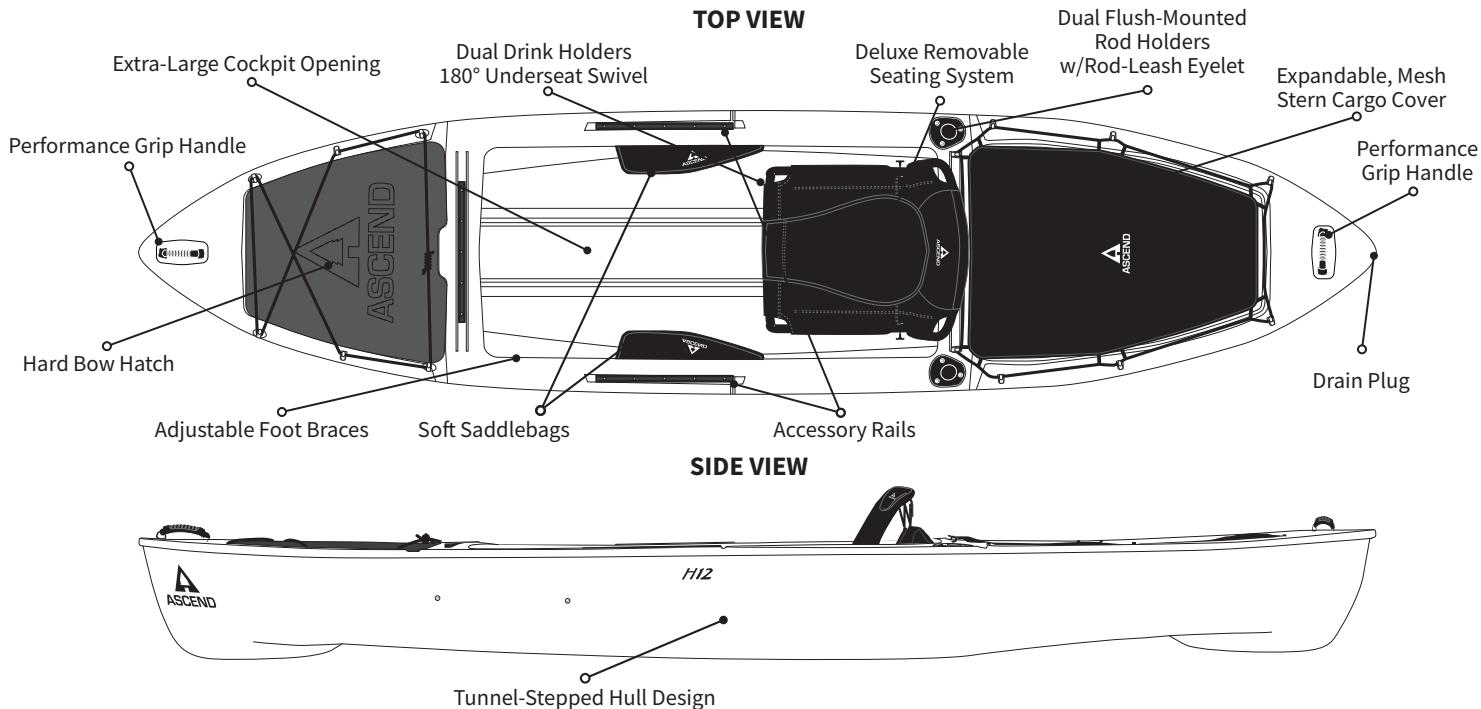

## 9R SPORT PRODUCT OVERVIEW

---

ASCEND designers focused on creating an all-round play boat for smaller adults and youth alike, delivering entry-level stability and maneuverability in a 9' recreational kayak. It is a great balance for the recreational paddler who wants a sit-on-top design with a taller seating system without all the weight. The 9R Sport is a lightweight, rotomolded boat with advanced ergonomic design. Molded-in drink holders and side pockets provide lots of stowage for drinks and snacks. The 4-strap adjustable seat features comfortable 1"-thick

**Tunnel Hull Design:** Recreational purpose, custom-crafted hull design delivers stability in flatter, calm waters recommended for smaller adults 5'10" and youth alike. Primary and secondary stability are the lowest rating of the ASCEND lineup due to the watercraft's size and high-seat profile.

**Adjustable Seating System:** A simple removable seating system has 4-point adjustment for multiple support options and closed-cell foam delivering all-day comfort.

**Mold-In Storage Trays and Drink Holders:** Deep molded, self-draining port and starboard draining holders and storage trays provide convenient access for drinks and various types of gear.

**Paddle Holders:** Recessed, molded parallel channels allow for temporary placement of the paddle.

neoprene over closed-cell foam which provides comfortable support for all-day adventures. The short length and light weight makes the 9R Sport easy to transport, portage, and store. The price makes the entire package a great overall value. From the rugged rotational molded design to the use of high-density material used in the molding process, paddlers will have years of enjoyment.

**Weather-tight Deck-Plate Storage:** Provides excellent storage for small items such as your wallet and keys. Secondary waterproof cases are recommended to ensure a great day on the water.

**Handles:** Molded-over rubber-grip bow handle and a molded stern handle make transporting the kayak a simple process.

**Scupper Drains:** Eight 1.5" (3.81cm) self-draining, molded thru-hull scuppers with 6 scupper plugs included.

**Drain Plug:** Threaded, sealed drain plug allows you to easily drain excess water from the boat.

# Kayak Anatomy

## 9R SPORT SIT-ON-TOP KAYAK

- Length: 9' (2.74m)
- Width: 31" (78.74cm)
- Weight w/Seat: 52 lbs. (23.59kg)
- Max. Capacity: 225 lbs. (102.06kg)

9R Sport model shown w/all accessories.  
Models and accessories will vary.

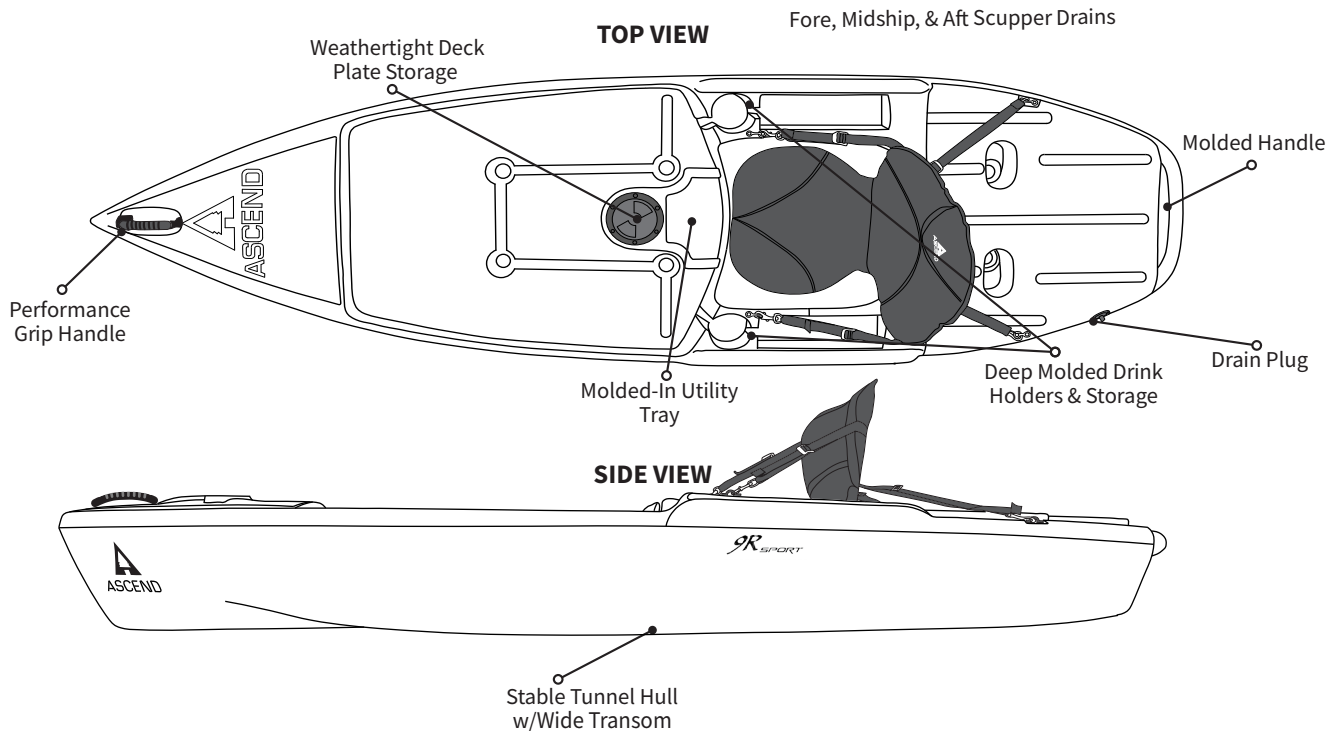

## 10T PRODUCT OVERVIEW

The unique hull design of the 10T sit-on-top kayak results in impressive maneuverability and a stable standing and fishing platform. The open-deck design is optimized for accessory customization and unique storage opportunities. The ultimate in comfort, the removable, suspended seating system is a modified

version of our popular deluxe seat. Standard features include an integrated weathertight storage deck plate and quick-connect D-ring attachments at the bow and stern. It also includes 3 rails that accept almost all aftermarket rail-mounted accessories (*accessories not included*).

**Tunnel Hull Design:** Custom-crafted, advanced design with a wide transom and flared bow sections to distribute displacement to provide maximum stability while standing and fishing, as well as solid tracking and easy paddling. Allows for convenient entry and exit on beaches and shorelines.

**Accessory Rails:** 3 rails recessed into the port, starboard, and forward midship deck landing maximize flexibility by allowing you to choose your own rigging locations and quickly add virtually any aftermarket accessory that attaches to a rail system (e.g., fish finders, flex-arm transducers, lights, rod tubes, rod tenders, and camera mounts) *Accessories not included*.

**Adjustable Foot Braces:** Allow a comfortable fit for anyone approximately 5'2"-6'4" (1.57-1.93m) tall. Can be moved fore and aft in concert with the 3-position seat adjustment to balance the load to maximize performance.

**Nonskid Foam Deck Mat:** Marine-grade, EVA-cushioned foam system is UV-resistant and extremely durable. Midship 6mm-thick deck pad provides comfort while standing, sitting, or kneeling, as well as excellent noise cancellation.

**Dual Flush-Mounted Rod Holders:** Allow secure transport of various types of rods and reels with quick access while on the water. Rod-leash ready.

**Deluxe Removable Seating System w/Friction-Lock Bungee Hold Downs:** Advanced ergonomic seat design with positive friction-lock bungee hold-downs for easy adjustments and all-day comfort. Can be removed for use onshore.

**Weathertight Deck-Plate Storage with Tethered Lid:** Provides excellent storage for small items, such as a wallet and keys. Secondary waterproof cases are recommended to ensure a great day on the water.

**Deep Molded Drink Holder:** Deep molded drink holder accommodates larger sport bottles or can be used as a quick storage solution for loose items you want readily accessible.

**D-Rings:** Powder-coated steel D-rings offer maximum versatility. 4 anchors in the bow and 4 in the stern allow you to secure a variety of gear with your choice of attachment, including carabiner, rope, bungees, or lightweight line.

**Performance Grip Handles:** Molded-over bow and stern rubber-grip handles for easy transport. Attached with 1/4" (.64cm) stainless steel bolts.

**Side Handles:** Port and starboard black powder-coated handles allow convenient side carrying.

**Scupper Drains:** Six 1.5" (3.81cm) self-draining molded thru-hull scuppers with 6 plugs included.

**Drain Plug:** Threaded, sealed drain plug allows you to easily drain excess water from the boat. Installed with stainless steel coarse-thread screws.



# Kayak Anatomy

## 10T SIT-ON-TOP KAYAK

- Length: 10' (3.05m)
- Width: 31" (78.74cm)
- Weight w/seat: 67 lbs. (30.39kg)
- Max. Capacity: 325 lbs. (147.42kg)

10T model shown w/all accessories. Models and accessories will vary.

### TOP VIEW

Fore, Midship, & Aft Scupper Drains  
w/6 Plugs

Dual Flush-Mounted  
Rod Holders  
w/Rod-Leash Eyelet

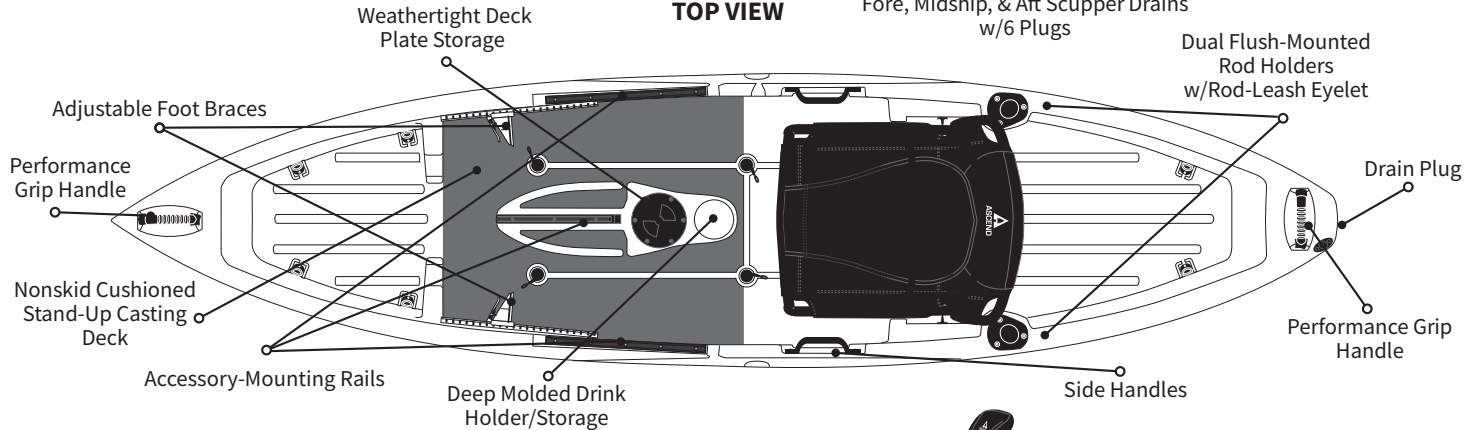

### SIDE VIEW

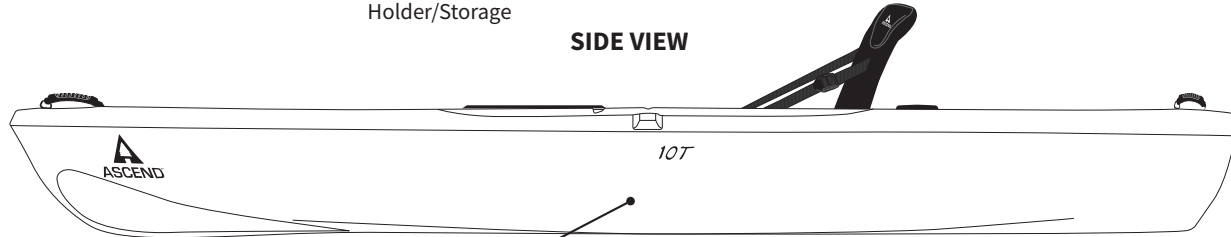

Stable Tunnel Hull  
w/Wide Transom & Flared Bow Sections

## 12T PRODUCT OVERVIEW

With the 12T, we took our most-popular sit-on-top model and redesigned it to be more stable, functional, and comfortable. It features comfortable deck mats, a testament to the meticulous attention to features and detail employed in its design. Using customer feedback, ASCEND® designers have built in a number

of other great features to create a user-friendly system ideally suited for beginning paddlers and avid anglers.

**Tunnel Hull Design:** Custom-crafted, advanced design with a wide transom and flared bow sections to distribute displacement to provide maximum stability while standing and fishing, as well as solid tracking and easy paddling. Allows for convenient entry and exit on beaches and shorelines.

**Midship Dash:** Ergonomic dashboard with catch-all trays for a convenient layout and great comfort while sitting or standing.

**Nonskid Cushioned Foam Deck Mat:** Marine-grade, EVA-cushioned foam system is UV-resistant and extremely durable. Midship 6mm-thick deck pad provides comfort while standing, sitting, or kneeling, as well as excellent noise cancellation.

**Accessory Rails:** Port and starboard gunnel flat-mounted accessory rails maximize flexibility by allowing you to choose your own rigging locations and quickly add virtually any aftermarket accessory that attaches to a rail system (e.g., fish finders, flex-arm transducers, lights, rod tubes, rod-tenders, and camera mounts) *Accessories not included.*

**Deluxe Removable Seating System:** Deluxe rail-mounted design with 3-position fore and aft adjustability for excellent load bearing and functionality. Can be removed for use onshore.

**Weathertight Storage w/Tethered Lid:** Provides excellent storage for small items, such as a wallet and keys. Secondary waterproof cases are recommended to ensure a great day on the water.

**Large Molded Sternwell:** Integrated D-rings allow you to secure a full-size cooler.

**Flat Casting Deck Footwell:** A solid casting platform while standing and fishing.

**Dual Flush-Mounted Rod Holders:** Allow secure transport of various types of rods and reels with quick access while on the water. Rod-leash ready.

**Flush-Mounted Paddle Holders:** Rigid starboard paddle-holders allow you to quickly stow the paddle parallel along the gunnel.

**Performance Grip Handles:** Molded-over bow and stern rubber-grip handles for easy transport.

**Adjustable Foot Braces:** Allow a comfortable fit for anyone approximately 5'2"-6'2" (1.57-1.88m) tall.

**Scupper Drains:** Six 1.5" (3.81m) self-draining molded thru-hull scuppers with 6 plugs included.

**Drain Plug:** Threaded, sealed drain plug allows you to easily drain excess water from the boat.

**Gaskets:** Die-cut EPDM foam gaskets on flush-mounted rod holders and drain plug to virtually eliminate water intrusion.

**Fasteners:** Hidden hatch fasteners for drier storage.

# Kayak Anatomy

## 12T SIT-ON-TOP KAYAK

12T model shown w/all accessories. Models and accessories will vary.

- Length: 12' (3.66m)
- Width: 31" (78.74cm)
- Weight w/Seat: 77 lbs. (34.93kg)
- Max. Capacity: 350 lbs. (158.76kg)

Fore, Midship, & Aft  
1.5" Scupper Drains w/6 Plugs

Flat Gunnel  
Landings for  
Mounting  
Optional  
Accessories

Weathertight  
Storage Hatch

Nonskid Cushioned  
Stand-Up Casting Deck

### TOP VIEW

Ergonomic Dash

Weathertight  
Deck-Plate  
Storage

Deluxe Removable  
Seating System

Performance  
Grip Handle

Performance  
Grip Handle

Recessed Bow &  
Stern  
Flush-Deck Bungee  
Mounting System

Drain Plug

Adjustable  
Foot Braces

Port & Starboard  
Accessory Rails

Deep Molded  
Drink Holder

Flush-Mounted  
Paddle Holders

3-Position Molded  
Seat Landings

Large Molded Stern  
Tankwell

### SIDE VIEW

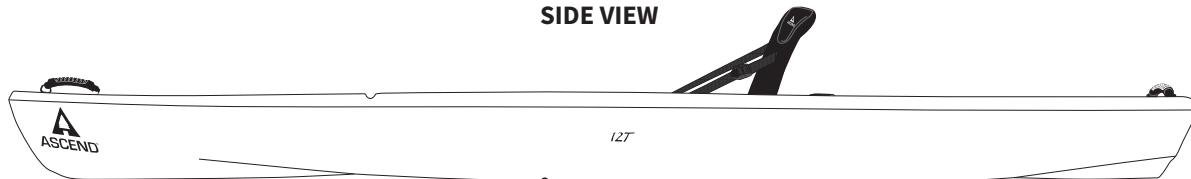

Extremely Stable Tunnel Hull Design

## 128X PRODUCT OVERVIEW (Yak-Power Equipped)

The 128X from ASCEND® is designed with a catamaran-style hull which provides abundant space and unprecedented stability. A nonskid deck mat allows comfortable standing, while a lightweight, removable, powder-coated aluminum high-back seating system maximizes comfort and fishability using ballistic nylon mesh and a breathable 3D soft poly mesh when you want to sit and relax. On-deck, the 128X sports an open design with 2 dedicated upright rod holders and in-gunnel lay-down rod storage,

plus multiple molded receivers for 3600-series tackle boxes. A 12V Yak-Power system with integrated electrical harness for plug and play installation of your fishing accessories, comes with 2 preinstalled ports, along with 1 auxiliary port that you can install for additional 12V accessories. Four 16" accessory rail mounts along with landings located midship allow the use of aftermarket accessories.

**Custom Catamaran Hull:** Designed to deliver maximum stability in almost any type of water. The catamaran hull provides excellent primary and secondary stability whether you choose paddling, or stern-mount electric propulsion.

**High-Back Seating System:** Improved freedom of movement, NEW ergonomic design eliminates shoulder-blade pinch and reduces pressure points. 600-denier ripstop polyester with increased UV resistance and durability. Adjustable nylon webbing strap. Intertreated ballistic nylon monofilament mesh and 3D soft polyester mesh for breathability and comfort in wet conditions. Fore and aft, as well as high and low preset adjustments.

**Pre-Wired for 12V Electronic Accessories:** A Yak Power wiring harness with circuit protection and master controller is preinstalled to power 12V electronics (not to exceed 15A), **will not support trolling motors**. Power ports are located in 2 locations for convenient connections. Waterproof master controller is pre-installed to accept 3 additional auxiliary connections. See Page 28 for further details.

**Stern Motor or Power Pole Ready:** The stern is equipped with industry standard 4-hole bolt pattern that allows the Torqueedo™ Stern Motor or Mini Power Pole to be mounted.

**Custom Molded Midship Dry-Storage Access Hatch:** Provides below-deck dry storage for 3600-series tackle trays, electronics batteries, etc. A below-seat storage tray, along with in-gunnel catchall trays, allow storage options for almost all fishing environments.

**Adjustable Foot Braces:** Allow a comfortable fit for almost anyone. This kayak was designed to easily convert to a cable foot-steering option if a stern motor is added.

**Accessory Rails:** 4 recessed accessory rails preinstalled to allow you to quickly add virtually any aftermarket accessory.

**Paddle/Rod Holders:** Port and starboard molded pockets allow paddle or rod positioning for multiple rods. Dual flush-mount rod tubes also included.

**Performance Grip and Side Load Assist Handles:** Molded-over nylon strap bow handle and molded-in stern handles make it easy to maneuver the 128X on land. 2 midkayak load-assist side handles also aid in loading and unloading from truck or trailer.

**Sacrificial Skid Pads:** We added sacrificial skid pads to the bow and stern so if you have to drag the kayak, the skid pads suffer the wear and can be replaced instead of damaging the hull.

**Scupper Drains:** Eight 1.5" (3.8cm) self-draining molded thru-hull scuppers also included for deck drainage. In addition, a threaded, sealed drain plug allows you to easily drain excess water from the boat cavity.



# Kayak Anatomy

## 128X SIT-ON-TOP KAYAK

128X model shown w/all accessories. Models and accessories will vary.

- Length: 12' 8" (3.86m)
- Width: 34" (86.4cm)
- Weight w/seat: 96 lbs. (43.5kg)
- Max. Capacity: 450 lbs. (204.12kg)

Fore, Midship, & Aft  
Scupper Drains w/8 Plugs

Yak-Power System w/Wiring Harness & Master  
Controller (see Page 28 for more system overview)

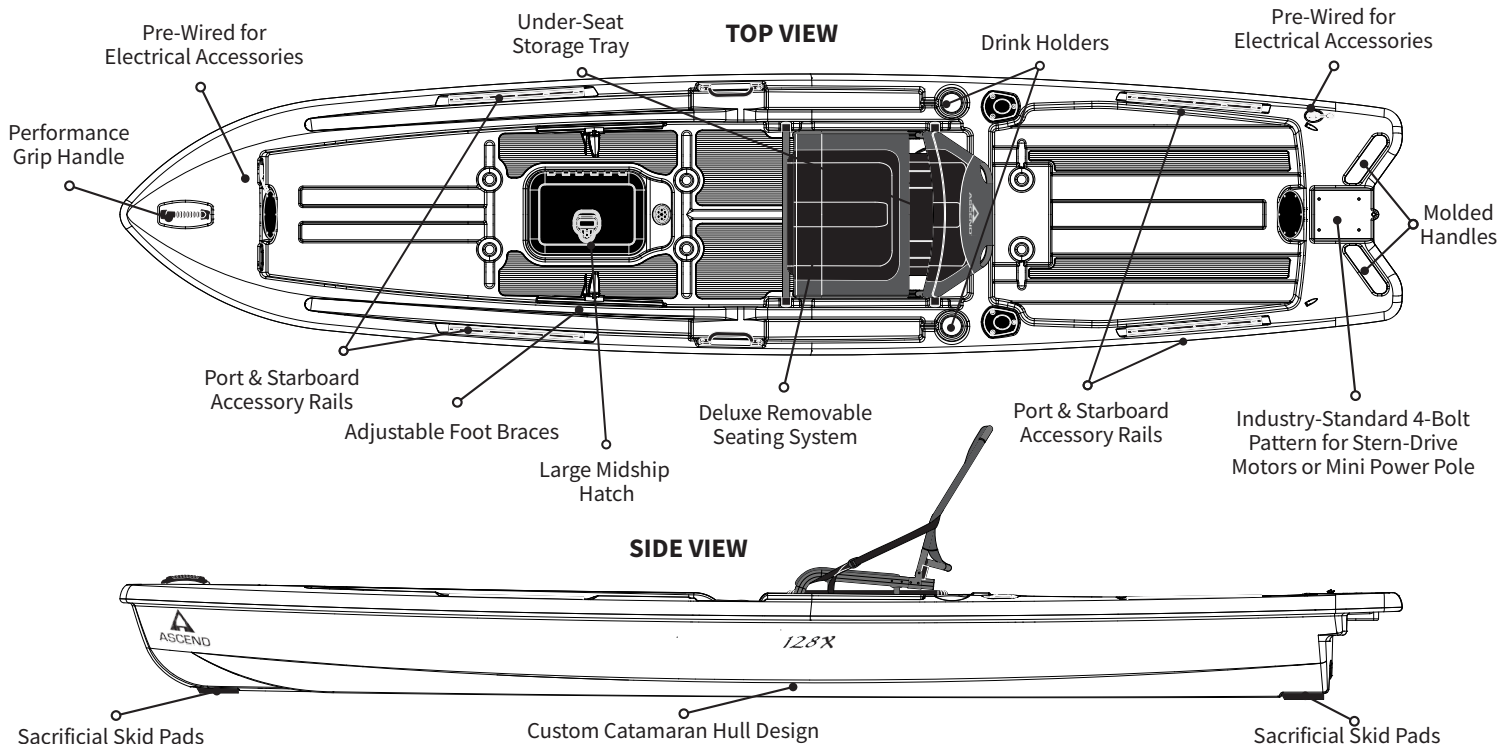

## 133X TOURNAMENT KAYAK PRODUCT OVERVIEW

The 133X is the most advanced fishing watercraft ever from ASCEND®—and it's designed specifically for electric propulsion. An aircraft-carrier-style deck and catamaran-style hull provide massive space and unprecedented stability. A nonskid deck mat allows comfortable standing, and a lightweight, removable, powder-coated aluminum high-back seating system maximizes comfort and fishability using ballistic nylon mesh and a breathable 3D soft polyester mesh. On deck, the 133X sports an open design with 2 dedicated

upright rod holders and in-gunnel lay-down rod storage, plus multiple molded receivers for 3600-series tackle boxes. An integrated electrical harness for plug and play installation includes 50A circuit protection for bow and/or stern electric motors. A 12V Yak-Power system with 2 ports is preinstalled, along with 3 auxiliaries that you can install for additional 12V accessories. Four 16" accessory rail mounts along with landings located midship allow use of aftermarket accessories.

**Custom Catamaran Hull:** Designed to deliver maximum stability in almost any type of water. Excellent primary and secondary stability whether you choose paddling, bow mount, stern mount, or both types of electric propulsion!

**High-Back Seating System:** Improved freedom of movement. NEW ergonomic design eliminates shoulder-blade pinch and reduces pressure points. 600-denier ripstop polyester with increased UV resistance & durability. Adjustable nylon webbing strap. Integrated ballistic nylon monofilament mesh and 3D soft polyester mesh for breathability and comfort in wet conditions. Fore and aft, as well as high and low preset adjustments.

**Pre-Wired for Electric Motors:** A preinstalled wire harness with 50A circuit protection is installed to simplify the installation of a Minn Kota® or MotorGuide® bow-mount trolling motor (See Page 27 for further details and motor recommendations).

**Pre-Wired for 12V Electronic Accessories:** A Yak-Power wiring harness with circuit protection and master controller is preinstalled to power 12V electronics (not to exceed 15 amps), excluding trolling motors. Power ports are located in 3 locations for convenient connection. Waterproof master controller is pre-terminated to accept 2 additional auxiliary connections (See Page 27 for further details).

**Stern Motor & Power Pole Ready:** The Stern has 3 locations for power poles with industry standard 4-hole bolt pattern that also allows the Torqueedo™ Stern Motor to be mounted in the center pattern and 2 power poles on each side, or mount the power pole in the center if running a bow-mount motor only.

**Bow-Mount Motor Control:** Includes uninstalled motor-lock release and dual-handle retraction system to allow deployment and stowing from the seated position.

**Custom Molded Midship Dry-Storage Access Hatch:** Provides below-deck dry storage for 3600-series tackle trays, electronics batteries, etc. A below-seat storage tray, along with in-gunnel catchall trays, allow for all types of great storage options for almost all fishing environments.

**Adjustable Foot Braces:** Allow a comfortable fit for almost anyone. This Kayak was designed to easily convert to a cable foot-steering option if a stern motor is added.

**Accessory Rails:** 4 recessed accessory rails preinstalled to allow you to quickly add virtually any aftermarket accessory.

**Paddle/Rod Holders:** Port and starboard molded pockets allow paddle or rod positioning for multiple rods. Dual flush-mount rod tubes also included.

**Thru-Hull Transducer Scupper:** Allows for 3-in-1 sonar, down scan and side scan transducers to be mounted in the under-hull recess.

**Scupper Drains:** Nine 1.5" (3.8cm) self-draining molded thru-hull scuppers also included for deck drainage. In addition, a threaded, sealed drain plug allows you to easily drain excess water from the boat cavity.

**Handles:** (4) Bow/stern molded handles with 2 side load assist side handles (Accessories not included).

# Kayak Anatomy

## 133X SIT-ON-TOP KAYAK

133X model shown w/all accessories. Models and accessories will vary.

- Length: 13' (3.96m)
- Width: 36.5" (92.7cm)
- Weight w/seat: 125 lbs. (56.7kg)
- Max. Capacity: 550 lbs. (249.48kg)

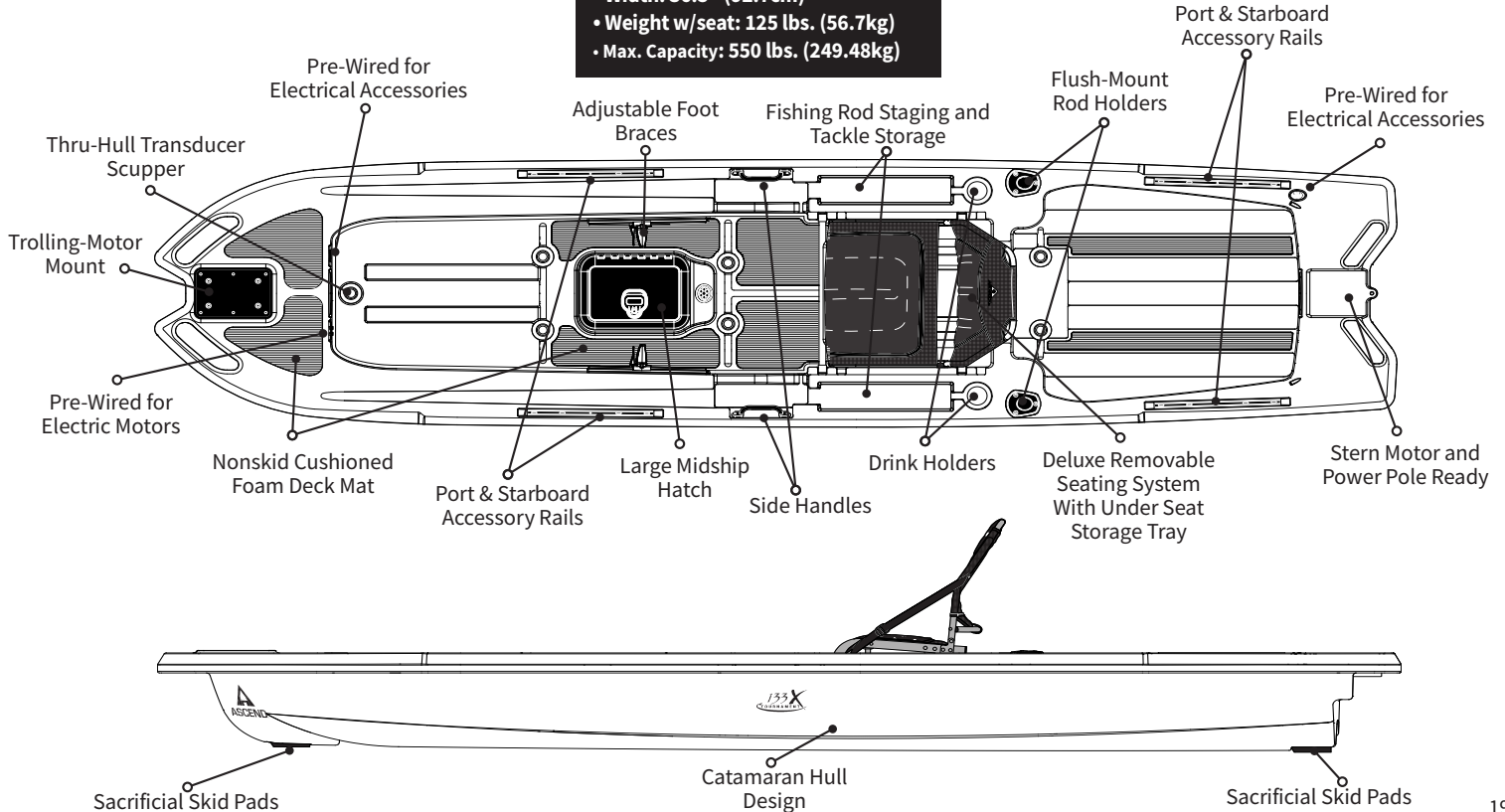

# ASCEND Model Overview – Sit In/Hybrid

	10Si	H10	H12
<b>Available Colors</b>			
	Magma	Arid	OG Camo
	Covert		
	Slate Blue		
	OG Camo		
<b>Seating</b>			
Seat included	X	X	X
Fore & aft base adjustment		X	X
Backrest adjustment	X	X	X
Height adjustment			
Adjustment strap system	Single	Single	Single
Friction-lock bungee hold-downs	X	X	X
<b>Storage</b>			
Style	Open	Open	Open
Bow hatch		Open	Open
Bow storage	Closed	Open	Open
Bow hold-downs	Bungees	Bungees	Bungees
Weathertight deck plate			
Stern storage	Open	Open	Open
Stern hold-downs		Bungees	Bungees
Large hatch (13.7"L x 23.36"W)			
Medium hatch (10.91"L x 14.84"W)			
Port & starboard saddlebags		X	X
Seat-back pack			X
<b>Fishing</b>			
Preinstalled accessory rails	6" (2) & 12" (2)	16" (3)	16" (3)
Flush-mounted rod holders		2	2
Stand-up assist strap			
Rod-tip protector			
<b>Features</b>			
Cleats			
Adjustable foot braces	X	X	X
Nonskid cushioned flooring			
Quick-position paddle holders	X		
Fixed paddle keeper	2		
Adjustable cargo mesh cover	Stern (1)	Bow (1) & Stern (1)	Stern (1)
Scupper drains (plugs included)			
Performance grip handles (bow & stern)	X	X	X
Carrying capabilities	Gunnels/sides	Gunnels/sides	Gunnels/sides
Threaded, sealed drain plug	X	X	X



## ASCEND® Model Performance Rating Matrix – Sit In/Hybrid

The kayak lineup delivers a unique mix of performance, functionality, and comfort for all skill levels. At ASCEND®, we pride ourselves on crafting wide, stable platforms that are safe and comfortable. ASCEND kayaks offer a combination of reasonable paddling speed with versatile designs to

deliver the most comfortable ride possible. We also craft each boat from superior materials with state-of-the-art equipment and processes. Please use the following guide to identify the best match for your primary fishing and paddling waters.

	Sit-In/Hybrid (H)   Sit-In (Si)		
Performance Rating	10Si	H10	H12
Tracking	★★★★☆	★★★★★	★★★★★
Maneuverability/River Capability	★★★★☆	★★★★☆	★★★★☆
Primary Stability	★★★★☆	★★★★★	★★★★★
Secondary Stability	★★★★★	★★★★★	★★★★★
Standing Ability	★★★★☆	★★★★☆	★★★★☆
Speed	★★★★☆	★★★★☆	★★★★☆
Pre-Rigged for Fishing	No	Yes	Yes
Offshore Capability	★★★☆☆	★★★☆☆	★★★☆☆
Recreational Capability	★★★★★	★★★★★	★★★★★
<b>Specs/Stats</b>			
NMMA Certified	X	X	X
Single or Tandem	Single	Single	Single
1-Piece Rotomolded Construction	X	X	X
Hull type	Tunnel	Tunnel	Tunnel
Length	10' 2" (3.10m)	10' (3.05m)	12' (3.66m)
Width	32.9" (83.56cm)	31" (78.74cm)	32" (81.28cm)
Height (Bow, Center, Stern)	14.9", 14.5", 14.7" (37.85cm, 36.83cm, 37.34cm)	14.6", 13.1", 14.6" (37.08cm, 33.35cm, 37.08cm)	14.1", 12.1", 14" (35.86cm, 30.78cm, 35.56cm)
Bow Compartment	N/A	20.9"L x 18"W (53.09cm x 45.72cm)	23.4"L x 22.2"W (59.44cm x 56.39cm)
Stern Compartment	23.3"L x 21.3"W (59.18cm x 54.1cm)	23.8"L x 22.5"W (60.45cm x 57.15cm)	33.5"L x 23.6"W (85.09cm x 59.94cm)
Weight Capacity	350 lbs. (158.76kg)	400 lbs. (181.44kg)	450 lbs. (204.12kg)
Weight	57 lbs. (25.85kg)	55 lbs. (24.95kg)	76 lbs. (34.47kg)
Cockpit Opening	38.3"L x 23.9"W (97.28cm x 60.71cm)	47.4"L x 23.6"W (1.2m x 59.94cm)	53.5"L x 23.6"W (1.36m x 59.94cm)

# ASCEND Model Overview – Sit On Top

	Sit-on-Top				
	9R Sport	10T	12T	128X	133X Tournament
<b>Available Colors</b>					
	Lt. Blue/Purple	Arid	Arid	Stealth	Stealth
	Yellow/Orange	Covert	Covert		
<b>Seating</b>					
Seat included	X	X	X	X	X
Fore & aft base adjustment		X	X	X	X
Backrest adjustment	X	X	X	X	X
Height adjustment				X	X
Adjustment strap system	Dual	Single	Single	Dual	Dual
Friction-lock bungee hold-downs			X		
<b>Storage</b>					
Style	Open	Open & Closed	Open & Closed	Open & Closed	Open & Closed
Bow hatch			Open	Open	Open
Bow storage		Open	Open	Open	Open
Bow hold-downs		D-rings	Bungees		
Weathertight deck plate	X	X	X		
Stern storage		Open	Open	Open	Open
Stern hold-downs		D-rings	Bungees		Bungees
Large hatch (13.7"L x 23.36"W)					
Medium hatch (10.91"L x 14.84"W)			X	X	X
<b>Fishing</b>					
Preinstalled accessory rails		12" (1) & 16" (2)	16" (2)	16" (4)	16" (4)
Flush-mounted rod holders		2	2	2	2
<b>Features</b>					
Cleats					
Adjustable foot braces		X	X	X	X
Nonskid cushioned flooring		X	X	X	X
Quick-position paddle holders	X	X	X		
Fixed paddle keeper			1		
Adjustable cargo mesh cover					
Scupper drains (plugs included)	8 (0)	6 (6)	6 (6)	8 (8)	9 (9)
Performance grip handles (bow & stern)	X	X	X	X	
Carrying capabilities		Handles (2)		Molded Handles (2)	Molded Handles (4)
Threaded, sealed drain plug	X	X	X	X	X

## ASCEND® Model Performance Rating Matrix – Sit On Top

The kayak lineup delivers a unique mix of performance, functionality, and comfort for all skill levels. At ASCEND®, we pride ourselves on crafting wide, stable platforms that are safe and comfortable. ASCEND kayaks offer a combination of reasonable paddling speed with versatile designs to deliver

the most comfortable ride possible. We also craft each boat from superior materials with state-of-the-art equipment and processes. Please use the following guide to identify the best match for your primary fishing and paddling waters.

	Sit-on-Top				
Performance Rating	9R	10T	12T	128X	133X Tournament
Tracking	★★★★☆	★★★★★	★★★★★	★★★★★	★★★★★
Maneuverability/River Capability	★★★★☆	★★★★★	★★★★☆	★★★★☆	★★★★☆
Primary Stability	★★★★☆	★★★★☆	★★★★★	★★★★★	★★★★★
Secondary Stability	★★★★☆	★★★★☆	★★★★★	★★★★★	★★★★★
Standing Ability	N/A	★★★★☆	★★★★★	★★★★★	★★★★★
Speed	★★★★☆	★★★★☆	★★★★☆	★★★★☆	★★★★☆
Pre-Rigged for Fishing	No	Yes	Yes	Yes	Yes
Offshore Capability	N/A	★★★★☆	★★★★☆	★★★★☆	★★★★☆
Recreational Capability	★★★★★	★★★★★	★★★★★	★★★★★	★★★★★
<b>Specs/Stats</b>					
NMMA Certified	X	X	X	TBD	X
Single or Tandem	Single	Single	Single	Single	Single
1-Piece Rotomolded Construction	X	X	X	X	X
Hull type	Tunnel	Tunnel	Tunnel	Catamaran	Catamaran
Length	9' (2.74m)	10' (3.05m)	12' (3.66m)	12'8" (3.86m)	13' (3.97m)
Width	31" (78.74cm)	29.5" (78.74cm)	31" (78.74cm)	34" (86.4cm)	36.5" (92.7cm)
Height (Bow, Center, Stern)	12.7", 12.7", 9.9" (32.26cm, 32.26cm, 25.15cm)	13.5" HOA (29.85cm)	11.1", 11", 10.9" (28.27cm, 27.94cm, 27.64cm)	13.63", 12.6", 12.75" (34.63cm, 12.6cm, 32.39cm)	14.5" HOA (36.83cm)
Bow Compartment	N/A	23.6"L x 18.5"W (59.94cm x 46.99m)	26.1"L x 21.9"W (66.29cm x 55.63cm)	29.8"L x 15"W (75.69cm x 38.1cm)	31"L x 21.2" W (78.74cm x 53.85cm)
Stern Compartment	N/A	25.9"L x 23.5" W (65.79cm x 59.69cm)	37.6"L x 23.1"W (95.5cm x 58.67cm)	34.2"L x 21.4"W (86.9cm x 54.36cm)	36.2"L x 29.4"W (91.95cm x 74.68cm)
Weight Capacity	225 lbs. (102.06kg)	325 lbs. (147.42kg)	350 lbs. (158.75kg)	450 lbs. (204.12kg)	550 lbs. (249.48kg)
Weight	52 lbs. (23.59kg)	67 lbs. (30.39kg)	77 lbs. (34.93kg)	96 lbs. (43.5kg)	125 lbs. (56.7kg)
Cockpit Opening	Open	Open	Open	Open	Open

# 128X Yak Power/12V Wiring Information

Battery or battery box installed under deck (battery or battery box not included)



**Caution:** Always pay attention to the actual wire colors of all Yak-Power accessory cables to ensure the RED (+) wire is connected into the correct plug.



**Caution:** Do not exceed a maximum 15A system load.



**Caution:** Not trolling-motor compatible.

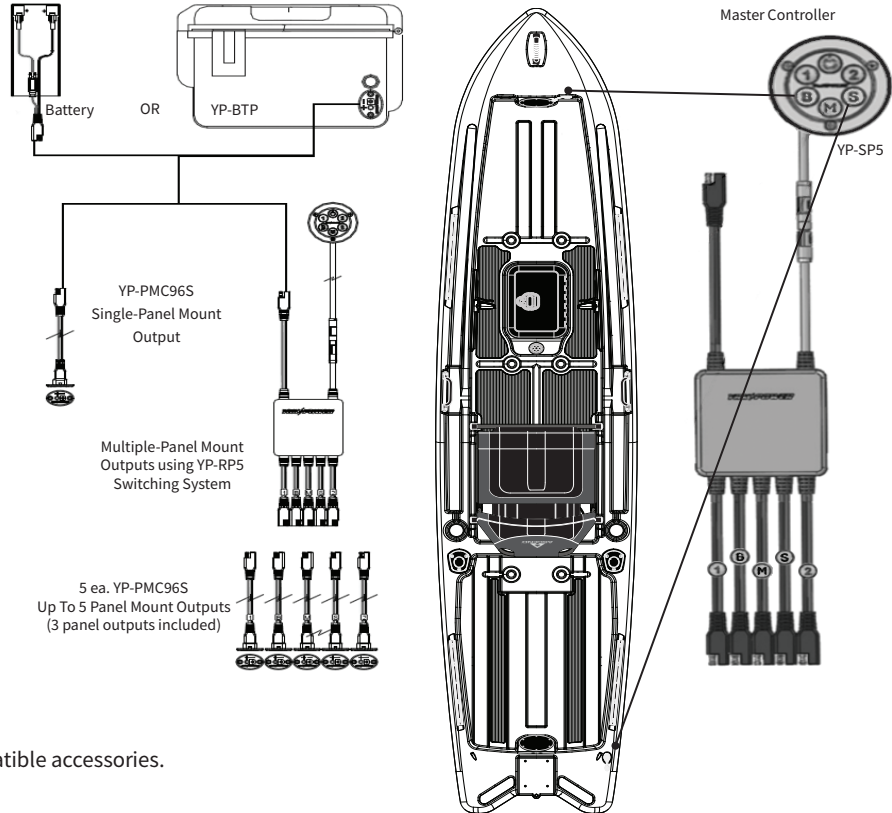

See your local dealer/retailer for all available compatible accessories.

# Yak Power/Trolling-Motor

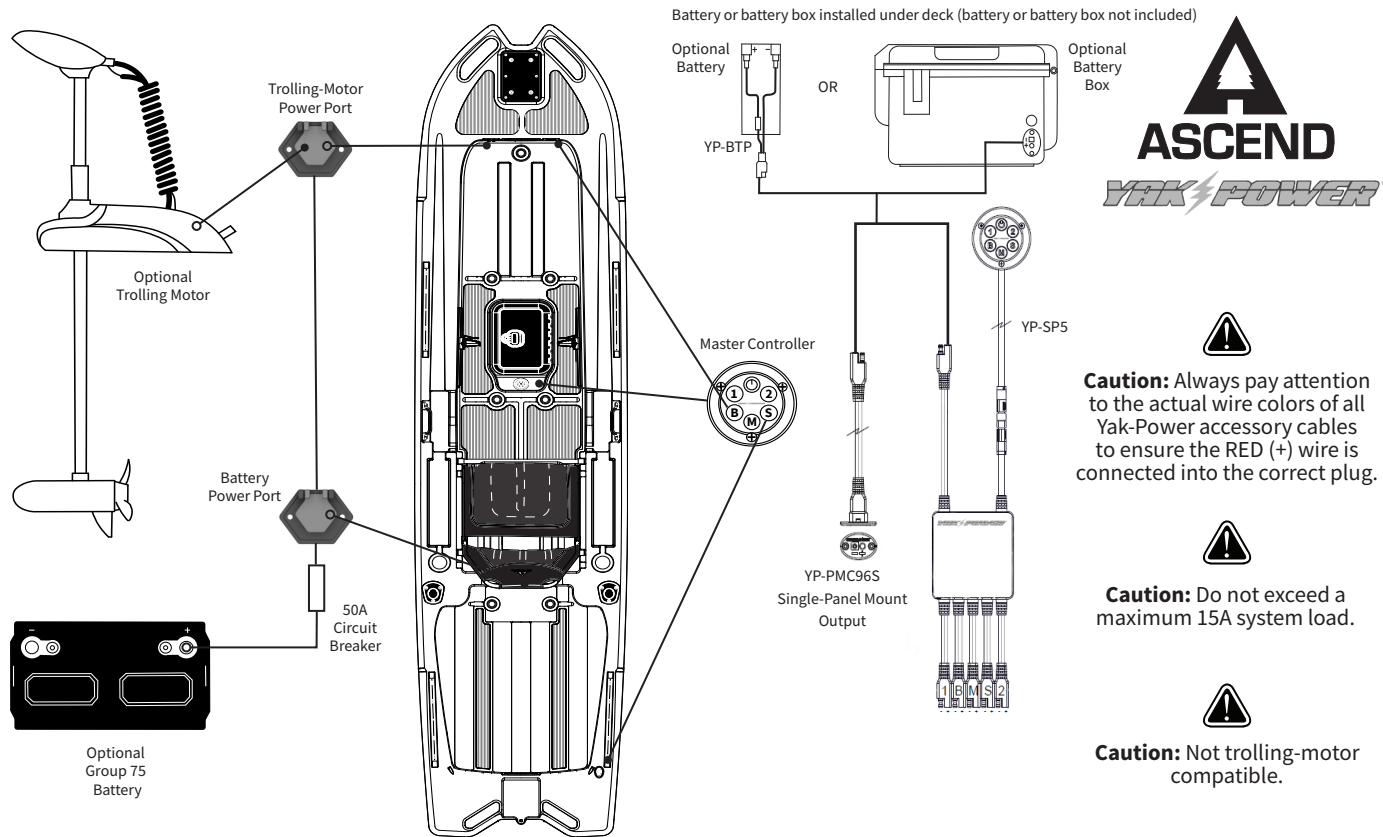

# 133X Trolling-Motor Options

## Motorguide

### Description

- Xi3 45-lb. thrust 48" shaft with remote control – 3-blade machete propeller
- Xi3 55-lb. thrust 48" shaft with remote control – 3-blade machete propeller
- Xi3 55-lb. thrust 48" shaft with GPS – 3-blade machete propeller
- Xi5 55-lb. thrust 45" shaft with Sonar and Pinpoint GPS
- Xi5 55-lb. thrust with Key Fob Saltwater 48" shaft – 3-blade machete propeller
- Motorguide Quick-Release Bracket
- Motorguide Pinpoint GPS NMEA 2000 Kit
- Pinpoint GPS Gateway Kit
- Digital Remote Control (Replacement)

## Minnkota

### Description

- Power Drive 45-lb. thrust 48" shaft (includes foot pedal)
- Power Drive 55-lb. thrust 48" shaft (includes foot pedal)
- Co Pilot (Remote)
- Terrova
- Minnkota Composite Quick-Release Bracket

## Optional Accessories

### Electric Drive Motors

- Bixpy Outboard Motor for Kayaks
- Torqueedo Ultralight Outboard Motor for Kayaks

### Shallow Water Anchor

- Power Pole Micro Anchor



## Universal Accessory Rail Overview

Quickly attach virtually any aftermarket rail mount accessory! ASCEND® fishing models feature preinstalled rail systems to deliver maximum rigging versatility for anglers and paddlers. **Accessories shown are not included—models include rails only.**

### Accessory Examples

- Fish finder and depth finder mounts
- Flex-arm transducer mounts
- Camera mounts
- Rod-tender mounts
- Miscellaneous electronic mounts
- Paddle mounts
- Leashes
- Improve all accessory, paddling, fishing, or anchor line management
- Aftermarket fishing accessories—rig them how you want
- Accepts RAILBLAZA®, RAM Mounts®, YakAttack®, and many more

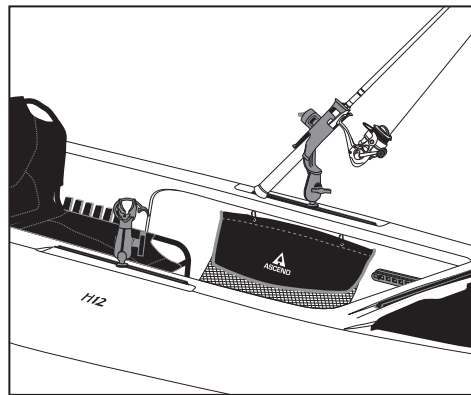
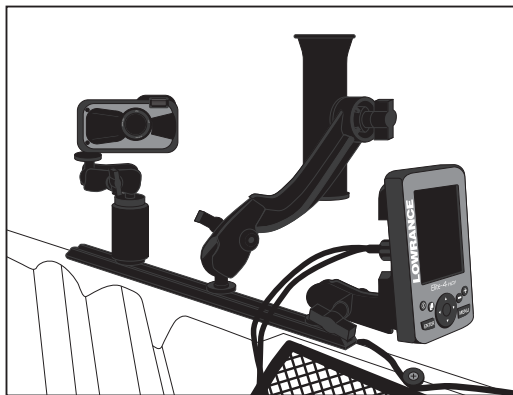

Rail lengths will vary by model. See individual kayak model pages for more details.



## ADJUSTING YOUR KAYAK'S FOOT BRACES

The ASCEND® kayak foot-brace system makes it easy to adjust your pedal position while seated. The foot braces have been customized to fit your particular boat for maximum comfort.

### PEDAL ADJUSTMENT

The design allows you to easily adjust the foot braces up to 15" (38.1cm). Simply pull the lever to release the lock. The foot brace will slide freely to the desired position. Release the lever to lock the foot-brace in place.

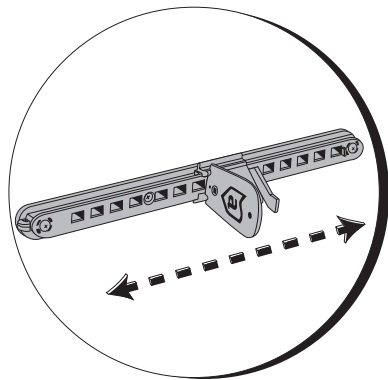

The adjustment lever can be pulled toward you with the opposite foot to create hands-free adjustment, if necessary.

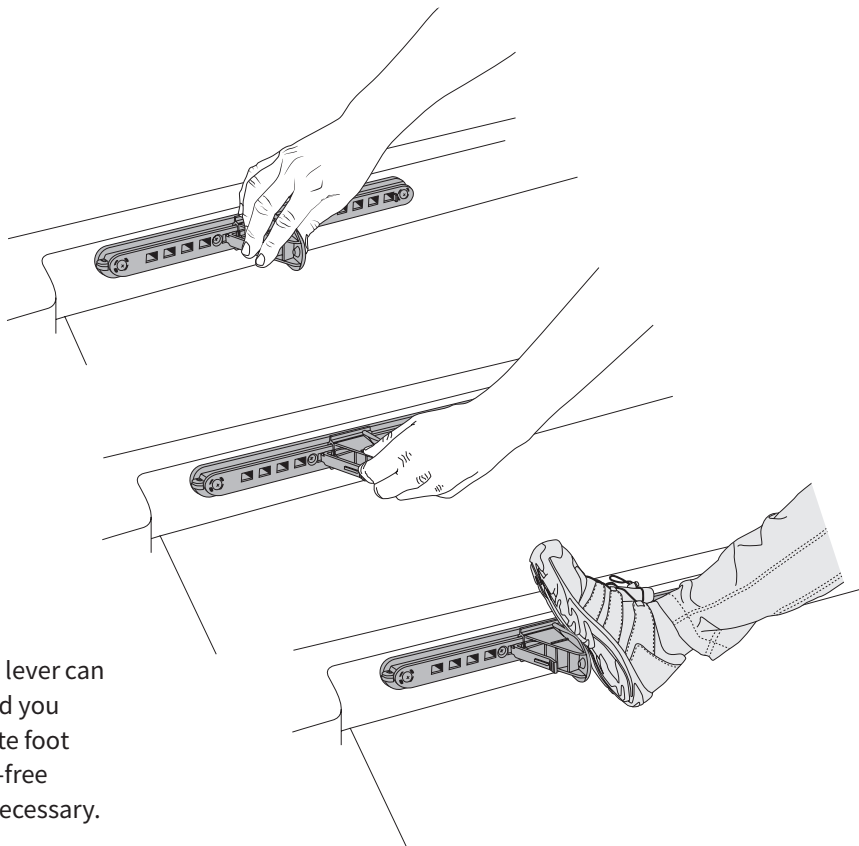

## ADJUSTING YOUR KAYAK'S SEAT (H10, H12, 10T, AND 10SI) Rail-&Side Engagement Model Designs



### H10, H12, & 10T Seat

**Step 1** – Choose one of the seat position slots.

**Step 2** – Engage the side washer seat guide into the seat slot. Ensure the washer engagement is underneath the looped bungee.

**Step 3** – Engage the opposite side seat guide into the seat slot. Ensure the washer engagement is underneath the looped bungee.

**Step 4** – Apply pressure and tighten the tension lock against the seat engagement slot until the seat is firmly held in place.

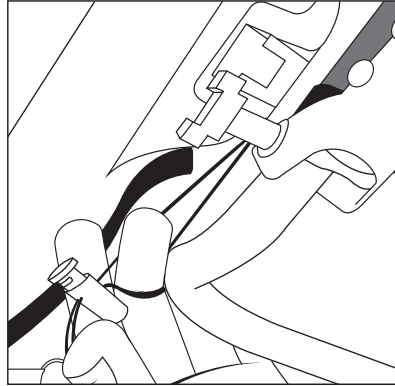

### 10SI Seat

**Step 1** – Confirm the nylon rail guide is underneath loop, as pictured, on each side.

**Step 2** – Engage the nylon rail guide into rail.

**Step 3** – Apply pressure and tighten the tension lock against the seat rail mounts until the seat is firmly held in place.

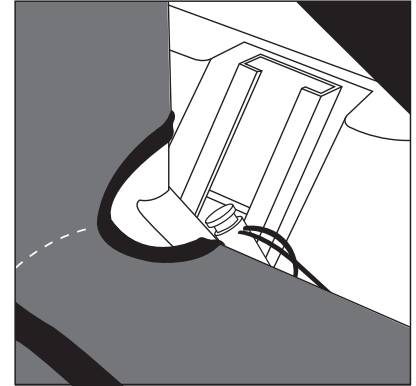

### 12T SEATING SYSTEM

The 12T seating system comes fully assembled and ready to install into the rail guides, as shown below. Please follow the step-by-step overview:

**Step 1** – Confirm alignment of guides with rails.

**Step 2** – Engage the first guide halfway into the rail.

**Step 3** – Engage the final guide into the rail while applying downward pressure.

**Step 4** – Slide the seat to the desired molded landing for maximum comfort and performance on the water.

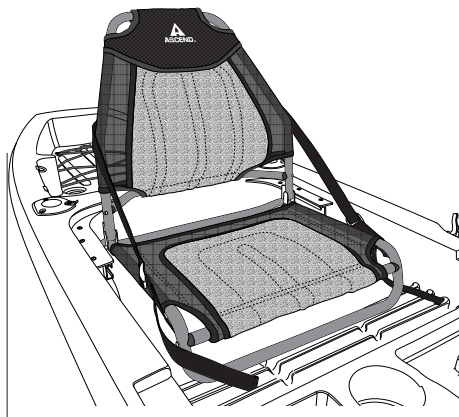
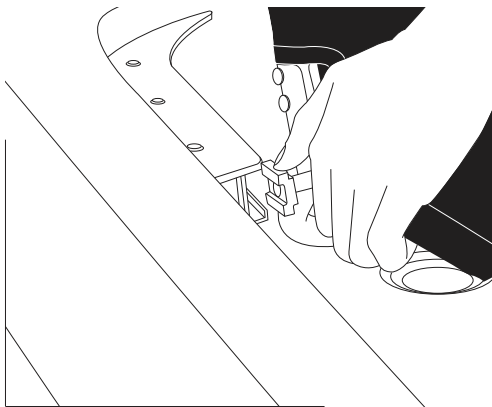

# GENERAL KAYAK INFORMATION

## Storage, Care, & Maintenance

ASCEND® recommends using a freshwater rinse and/or wipe down to keep your kayak clean, especially in saltwater conditions. Make sure you thoroughly rinse and clean all moving parts, including the adjustable foot braces and adjustment points.

A dry, cool, shaded area is the ideal storage environment. There are multiple storage rack systems available to protect your investment.

## Transporting Your Kayak

For safe and secure kayak transportation, we highly recommend that you install a rigid bar or sport rack system on your vehicle.

Your boat will be most stable when loaded and secured upside-down.

Avoid overtightening hold-downs in the center portion of the hull during extreme heat for extended periods of time, as this can cause the kayak to warp.

### IMPORTANT

We recommend vertical storage from keel to bow, or deck side down to prevent warpage to the hull. Do not store the kayak on its side. Do not ratchet down the hull further than 24" in from the bow or stern.

## Choosing the Right Paddle

The most common paddle lengths range from 220cm–250cm. The wider the kayak, the longer the paddle should be.

ASCEND kayaks are performance-engineered with a wider hull for maximum stability. We recommend you choose a longer paddle for the Sit-In and Sit-On-Top recreational models. A longer paddle used in concert with the wider hull will enhance performance and tracking and result in easier paddling.

## Recommended Equipment

### Safety

- Personal flotation device (PFD) – A comfortable and securely-fitting PFD should be worn at all times on the water
- Bilge pump to remove interior standing water
- USCG-approved horn or whistle (required)
- First-aid kit
- Marine radio

### Personal

- Dry bag
- Compass
- Insect repellent
- Drinking water
- Sunscreen
- Sunglasses
- Dry towel
- GPS unit
- Lighter
- Navigation charts
- Waterproof matches
- Mobile phone
- Screwdriver
- Waterproof tape
- Waterproof flashlight
- Spare clothes
- Wide-brimmed hat

# ASCEND® Kayak Limited Warranty

Please call **417.873.5034** for more information.

**THIS LIMITED WARRANTY CONTAINS IMPORTANT INFORMATION ABOUT YOUR RIGHTS AND OBLIGATIONS, AS WELL AS LIMITATIONS AND EXCLUSIONS THAT MAY APPLY TO YOU. ANY DISPUTE OR CLAIM RELATED TO THIS LIMITED WARRANTY OR YOUR PURCHASE OF THE ASCEND KAYAK MUST BE RESOLVED BY ARBITRATION ON AN INDIVIDUAL BASIS, AND MAY NOT BE ARBITRATED OR OTHERWISE PURSUED AS A CLASS ACTION. PLEASE SEE SECTION 9.**

**1. Warrantor.** This Limited Warranty on your ASCEND® kayak is provided by the manufacturer, White River Marine Group, LLC (“White River”, “we” and “us”), subject to the terms and conditions set forth herein. White River’s address is 2500 East Kearney Street, Springfield, Missouri 65898.

**2. What This Limited Warranty Covers, And For How Long.** Except as limited herein, this Limited Warranty covers parts and labor to correct defects in the materials and workmanship of your ASCEND kayak for three (3) years from the date of purchase.

**3. What This Limited Warranty Does Not Cover.** This Limited Warranty does not cover any of the following:

- Any defect caused by misuse, neglect, or an accident
- Any part, component, or accessory that has been modified, neglected, vandalized, or repaired or replaced with an unauthorized part, component, or accessory

- Any damages due to ordinary wear and tear
- Any damages or defects caused by improper storage or maintenance (see Ascend® Kayak Owner’s Manual for storage, care, and maintenance information)
- Any damages incurred in transporting the kayak to us for service under this Limited Warranty
- Any fees or damages you may incur (such as for storage, inconvenience, or loss of time or money) while a claim under this Limited Warranty is being processed

**4. Who May Enforce This Limited Warranty.** This Limited Warranty is personal to and extended only to the original retail purchaser of the ASCEND kayak, and is not transferable to any other person or entity under any circumstances.

**5. How To Request Service If You Have A Claim Under This Limited Warranty.** To request service under this Limited Warranty, please call us at 417.873.5034, and we will provide you with instructions regarding where to deliver or ship your ASCEND kayak. Any costs you incur to deliver or ship your ASCEND kayak to the designated place for warranty work are your sole responsibility. When you deliver or ship your ASCEND kayak to the designated place for warranty work, you must include a copy of the original proof-of-purchase for the kayak, and specify in writing the model and serial number of the kayak. We reserve the right to return the kayak to

## ASCEND® Kayak Limited Warranty (continued)

you at your expense—for example, by cash-on-delivery (C.O.D.) shipping—if the foregoing conditions and requirements have not been met.

**6. What We Will Do.** For any defect to your ASCEND kayak that qualifies for service under this Limited Warranty, White River will either (in our sole and absolute discretion) repair or replace the defective part, component, or accessory.

**7. Limitation on Duration of Implied Warranties.** ANY IMPLIED WARRANTY APPLICABLE TO YOUR PURCHASE OF THE ASCEND KAYAK, INCLUDING THE IMPLIED WARRANTY OF MERCHANTABILITY AND THE IMPLIED WARRANTY OF FITNESS FOR A PARTICULAR PURPOSE, IS HEREBY LIMITED IN DURATION TO THE DURATION OF THIS LIMITED WARRANTY OR THE MAXIMUM STATUTORY PERIOD, WHICHEVER IS LESS. SOME STATES DO NOT ALLOW LIMITATIONS ON THE DURATION OF IMPLIED WARRANTIES, SO THE FOREGOING LIMITATION MAY NOT APPLY TO YOU.

**8. Limitation of Damages.** IN NO EVENT WILL WHITE RIVER BE LIABLE FOR ANY CONSEQUENTIAL, INCIDENTAL, EXEMPLARY, OR SPECIAL DAMAGES ARISING FROM OR RELATING TO THIS LIMITED WARRANTY. SOME STATES DO NOT ALLOW THE EXCLUSION OR LIMITATION OF CONSEQUENTIAL OR INCIDENTAL DAMAGES, SO THE FOREGOING LIMITATION MAY NOT APPLY TO YOU.

**9. Dispute Resolution.** WHITE RIVER'S GOAL IS TO RESOLVE ANY WARRANTY ISSUE AS QUICKLY AND FAIRLY AS POSSIBLE. PLEASE CONTACT US AT 417.873.5034 IN THE EVENT YOU HAVE ANY QUESTIONS ABOUT THE TERMS, CONDITIONS, OR LIMITATIONS CONTAINED IN THIS LIMITED WARRANTY. THE PROCEDURE TO HAVE YOUR LIMITED WARRANTY ISSUE RESOLVED IS SET FORTH ABOVE. IN THE EVENT WE DO NOT REMEDY THE DEFECT WITHIN A REASONABLE TIME, YOU AGREE TO WRITE US AT WHITE RIVER CUSTOMER SERVICE, 2500 EAST KEARNEY STREET, SPRINGFIELD, MISSOURI 65898, AND TO EXPLAIN THE ISSUE. IF OUR RESPONSE TO YOUR WRITTEN EXPLANATION OF THE ISSUE IS NOT TO YOUR SATISFACTION, YOU AGREE THAT THE FOLLOWING BINDING ARBITRATION WILL APPLY.

### **BINDING ARBITRATION & CLASS ACTION WAIVER**

- a) You and White River agree to submit all disputes, claims, or controversies of any kind arising out of or related to this Limited Warranty and/or your purchase of the ASCEND kayak for resolution exclusively through binding and final arbitration, instead of through court proceedings. You should review this arbitration provision (this Section 9) carefully; it limits your and our ability to litigate claims in court. THIS AGREEMENT TO ARBITRATE MEANS THAT YOU AND WE WAIVE ANY RIGHT TO A TRIAL BY JURY, WHETHER ON AN INDIVIDUAL OR A CLASS BASIS.
- b) Arbitration is usually an informal proceeding in which disputes are decided by one or more neutral arbitrators who receive the evidence at a

## ASCEND® Kayak Limited Warranty (continued)

---

hearing and then issue a binding ruling in the form of an award. You and we understand that in an arbitration, discovery is more limited than in a court, and review by courts is very limited.

c) If either you or we intend to seek arbitration, such party must first send to the other party, by certified mail, a written Notice of Dispute (a “Notice”). Any Notice that you send to us must be addressed to General Counsel, White River Marine Group, LLC, 2500 East Kearney Street, Springfield, MO, 65898 (the “Notice Address”). Any Notice that we send to you will be sent to the contact information that we have on file for you. Any Notice must (i) describe the nature and basis of the dispute, claim, or controversy and (ii) set forth the specific relief sought. If you and we do not reach an agreement to resolve the dispute, claim, or controversy within 30 days after the Notice is received, you or we may commence an arbitration proceeding. During the arbitration, the amount of any settlement offer made by you or we shall not be disclosed to the arbitrator until after the arbitrator determines the amount, if any, to which you or we are entitled.

d) You and we agree, upon written demand made by you or us, to submit to binding arbitration of any and all disputes, claims, and controversies between you and us, whether based on statute, regulation, constitution, common law, equity, or any other legal basis or theory, and whether

pre-existing, present, or future, that arise out of or relate to this Limited Warranty and/or your purchase of the ASCEND kayak, including contract disputes, tort claims, fraud claims, fraud-in-the-inducement claims, misrepresentation claims, statutory claims and/or regulatory claims arising out of or relating to this Limited Warranty or your ASCEND kayak (including, to the fullest extent permitted by applicable law, relationships with third parties who are not parties to this Limited Warranty or this arbitration provision), or the scope or enforceability of this Limited Warranty, including the determination of the applicability of this agreement to arbitrate, and/or any other relationship or dispute between you and us (each a “Claim”, and collectively the “Claims”). Any and all Claims shall be submitted for binding arbitration in accordance with the Consumer Arbitration Rules of the American Arbitration Association (the “AAA Rules”), as amended, in effect at the time arbitration is initiated. The AAA Rules are available online at [www.adr.org](http://www.adr.org) or by calling 800.778.7879. In the event of any inconsistency between this arbitration provision and the AAA Rules, such inconsistency shall be resolved in favor of this provision.

e) After the 30-day period specified in paragraph c) above has expired, either you or we may initiate arbitration by giving written notice of the intention to arbitrate to the other party and by filing notice with the AAA in accordance with the AAA Rules in effect at the time the notice is filed.



## ASCEND® Kayak Limited Warranty (continued)

We may be given notice at the Notice Address specified in paragraph c) above. If you decide to initiate arbitration, you agree to pay the initiation fee of \$200 (or the amount otherwise required by the AAA Rules), and we agree to pay the remaining arbitration initiation fee and any additional deposit required by AAA to initiate your arbitration. We will pay the costs of the arbitration proceeding, including the arbitrator's fees; however, other fees, such as attorney's fees and expenses of travel to the arbitration, shall be paid in accordance with the AAA Rules and applicable law. We will pay all costs associated with any arbitration that we commence.

f) A single, neutral arbitrator selected in accordance with the AAA Rules shall decide all Claims. The arbitrator shall be an active member in good standing of the bar for any state in the continental United States and shall be either actively engaged in the practice of law for at least five years or a retired judge.

g) You and we agree that the arbitrator shall: (i) limit discovery to non-privileged matters directly relevant to the Claim; (ii) grant only relief that is based upon and consistent with substantial evidence and applicable substantive law; (iii) have authority to grant relief only with respect to the Claims asserted by or against you and us individually; and (iv) provide a written statement stating the disposition of each Claim and a concise written explanation of the basis for the award and shall make specific findings of fact and conclusions of law to support any arbitration award.

Unless inconsistent with applicable law, and except as otherwise provided herein, each party shall bear the expense of its respective attorney, expert, and witness fees, regardless of which party prevails in the arbitration. Any arbitration proceedings shall be conducted in the federal judicial district of your residence, and you will be given the opportunity to attend the proceeding and be heard. If the Claim is for \$10,000 or less, we agree that you may choose whether the arbitration will be conducted solely on the basis of documents submitted to the arbitrator, through a telephonic hearing with the arbitrator, or by an in-person hearing in accordance with the AAA Rules.

h) The arbitrator's decision will be final and binding upon the parties and may be enforced in any federal or state court that has jurisdiction. You and we agree that the arbitration shall be kept confidential and that the existence of the proceeding and any element of it (including, without limitation, any pleadings, briefs or other documents submitted or exchanged, and any testimony or other oral submissions and awards) will not be disclosed beyond the arbitration proceedings, except as may lawfully be required in judicial proceedings relating to the arbitration or by applicable disclosure rules and regulations of securities regulatory authorities or other governmental agencies.

i) Demand for arbitration under this arbitration provision must be filed before the date when any judicial action upon the same Claim would be barred under any applicable statute of limitations; otherwise, the Claim

## ASCEND® Kayak Limited Warranty (continued)

is also barred in arbitration. Any dispute as to whether any statute of limitations, estoppel, waiver, laches, or other doctrine bars the arbitration of any Claim shall be decided by arbitration in accordance with this provision.

j) Neither you nor White River may act as a class representative or private attorney general, nor participate as a member of a class of claimants, with respect to any Claim. The Claims may not be arbitrated on a class or representative basis. The arbitrator can decide only your and/or White River's individual Claims. The arbitrator may not consolidate or join the claims of other persons or parties who may be similarly situated. Accordingly, you and we agree that the AAA Supplementary Rules for Class Arbitrations do not apply to our arbitration. This arbitration provision and the procedures applicable to the arbitration contemplated by this provision are governed by the Federal Arbitration Act, notwithstanding any state law that may be applicable.

k) This arbitration agreement does not preclude you or us from seeking action by federal, state, or local government agencies. You and we also have the right to exercise self-help remedies, such as set-off, or to bring qualifying claims in small claims court. In addition, you and we retain the right to apply to any court of competent jurisdiction for provisional or ancillary relief, including pre-arbitral attachments or preliminary

injunctions, and any such request shall not be deemed incompatible with the terms of this Limited Warranty, nor a waiver of the right to have disputes submitted to arbitration as provided in this provision.

l) You may choose to opt out of these arbitration procedures within 30 days from the date you purchase your ASCEND product ("*Opt Out Deadline*"). You may opt out of these arbitration procedures by completing the opt-out form located at [www.ascend-kayaks.com/arbitrationoptout](http://www.ascend-kayaks.com/arbitrationoptout) and sending the opt-out form by U.S. first-class mail, postage prepaid, to the following notice address: White River Customer Service, Attn: Arbitration Director, White River Marine Group, LLC, 2500 East Kearney Street, Springfield, Missouri 65898. Any opt-out received after the Opt Out Deadline will not be valid and you must pursue your Claims in arbitration or small claims court.

m) A court may sever any portion of this Section 9 that it finds to be unenforceable, except for the prohibitions on any Claim being handled on a class or representative basis, and the remaining portions of this arbitration provision will remain valid and enforceable. No waiver of any provision of this Section 9 will be effective or enforceable unless recorded in a writing signed by the party waiving such a right or requirement. Such a waiver shall not waive or affect any other portion of this Limited Warranty.

## ASCEND® Kayak Limited Warranty (continued)

---

n) THIS SECTION 9 LIMITS CERTAIN RIGHTS, INCLUDING THE RIGHT TO MAINTAIN A COURT ACTION, THE RIGHT TO A JURY TRIAL, THE RIGHT TO PARTICIPATE IN ANY FORM OF CLASS OR REPRESENTATIVE CLAIM, THE RIGHT TO ENGAGE IN DISCOVERY EXCEPT AS PROVIDED IN THE AAA RULES, AND THE RIGHT TO CERTAIN REMEDIES AND FORMS OF RELIEF. OTHER RIGHTS THAT YOU OR WHITE RIVER WOULD HAVE IN COURT ALSO MAY NOT BE AVAILABLE IN ARBITRATION.

**10. Choice of Law; Jurisdiction and Venue.** Except as set forth above, this Limited Warranty shall be governed exclusively by, and construed exclusively in accordance with, the internal laws of the state of Delaware without reference to the choice of law or conflicts of law principles thereof, and all claims relating to or arising out of this Limited Warranty, or the breach thereof, whether sounding in contract, tort, or otherwise, shall likewise be governed exclusively by the laws of the state of Delaware without reference to the choice of law or conflicts of law principles thereof. To the extent any action is permitted under the provisions above to be heard in a court of competent jurisdiction, such action shall take place in the state or federal courts sitting in Kent County, Delaware, the parties hereby waiving any claim or defense that such forum is not convenient or proper. Each party agrees that any such court shall have in personam jurisdiction over it for any such action, and each party consents to service of process in any manner authorized by Delaware law.

**11. Your Legal Rights.** This Limited Warranty gives you specific legal rights, and you may also have other rights which vary from state to state. To the extent any limitation or exclusion contained herein is contrary to any applicable law, such limitation or exclusion shall be severable and all other terms herein shall remain in full force and effect and are valid and enforceable.

**12. Other Information.** For all inquiries regarding your ASCEND kayak, please call 417.873.5034 from 9 A.M.–5 P.M. Central Time.

## ASCEND® Kayak Limited Warranty Arbitration Opt-Out Notice

---

I am writing to provide notice that I do not agree to and am opting out of the agreement to arbitrate contained in the ASCEND Kayak Limited Warranty.

Pursuant to the terms of the agreement to arbitrate contained in the ASCEND Kayak Limited Warranty, I am providing the requested information below and sending it by U.S. first-class mail, postage prepaid, to White River Marine Group Customer Service, Attn: Arbitration Director, White River Marine Group, LLC, 2500 East Kearney Street, Springfield, Missouri, 65898.

---

First & Last Name

---

Street Address, City, State, Zip Code

---

Phone Number

---

Email Address

---

Kayak Serial Number

---

Signature

---

Date

**Note:** This Arbitration Opt-Out Notice must be postmarked no later than 30 days after the date you purchased your ASCEND kayak. It is your responsibility to mail this Arbitration Opt-Out Notice by the applicable deadline.



# MANUFACTURER'S STATEMENT OF ORIGIN TO A BOAT

---

Manufacturer's Hull I.D. Number: \_\_\_\_\_

Type of Boat:       Kayak       Canoe       Pond Boat

Model: \_\_\_\_\_ Color: \_\_\_\_\_ Weight: \_\_\_\_\_

Length: \_\_\_\_\_ Width: \_\_\_\_\_ Height: \_\_\_\_\_

The Manufacturer certifies that this was the first transfer on this new boat and that all information is true and accurate to the best of its knowledge:

  
Authorized Signature

\_\_\_\_\_  
CFO  
White River Marine Group, LLC

*White River Marine Group, LLC • 2500 East Kearney, Springfield, Missouri, 65898*

# FIRST ASSIGNMENT

---

FOR VALUE RECEIVED, the undersigned hereby transfers this Statement of Origin and the boat described therein to

Address \_\_\_\_\_

and certifies that the boat is new and has not been registered in this or any other state; the undersigned also warrants the title of said boat at the time of delivery, subject to the liens and encumbrances, if any, as set out below:

AMOUNT OF LIEN:

DATE:

TO WHOM DUE:

ADDRESS:

_____	_____	_____	_____
_____	_____	_____	_____
_____	_____	_____	_____

Dated \_\_\_\_\_ year of \_\_\_\_\_, at \_\_\_\_\_

\_\_\_\_\_ By: \_\_\_\_\_  
Transfer or (Firm Name) Sign Here Position

Dealer License (Permit) Number: \_\_\_\_\_

## NOTARY STATEMENT

Before me personally appeared \_\_\_\_\_

who by me being duly sworn upon oath says that the statements set forth above are true and correct. Subscribed and sworn to before me this \_\_\_\_\_ day of \_\_\_\_\_, 2\_\_\_\_.

\_\_\_\_\_, Notary Public. Date Commission Expires: \_\_\_\_\_  
Signature





# ASCEND™

## ELEVATE YOUR EXPERIENCE!

From the most adventurous outdoorsman to a new generation waiting to be inspired, ASCEND® strives to outfit everyone with the highest quality gear at the best possible value. Our purpose is to instill a legacy of outdoor adventure, conservation and stewardship so future generations will share our passion for the outdoors.

**White River Marine Group LLC.**

**2500 East Kearney, Springfield, Missouri, 65898**

Photos may show optional or special edition equipment available at an additional cost. Details in pricing, savings, features, colors, accessories and promotions may vary by location and are subject to change without notice. Void where prohibited by law. Best efforts are used to ensure the accuracy of our advertising, however, errors may sometimes occur. See your local dealer for complete information. F.O.B. Springfield, MO, USA. © 2024 White River Marine Group, LLC